

# 2MP EXPLOSION PROOF PTZ CAMERA



## ENC-HPT5Z-30X-23

### FEATURES

304 / 316L Stainless Steel Construction

30X Optical Zoom, 16X Digital Zoom

ONVIF Profile (S, G, T)

Quad Stream

Audio and Alarm Support

Wiper Support

IP68

ATEX/ IECEx/ CCoE (PESO) Certified



### SPECIFICATION

MODEL	Model No.	ENC-HPT5Z-30X-23
	Type	2MP EXPLOSION PROOF PTZ CAMERA
CAMERA	Image Sensor	1/2.8" CMOS Progressive 2.0 MegaPixel
	Day / Night	IR Cut Filter with Auto Switch
	Lens Type	Motorized Lens
	Focal Length	4.5-135 mm (Optional 4.3 to 129mm) Lens
	Focus	Auto / Semi Auto/ Manual
	Iris Type	DC Auto Iris
	Angle of View (H)	60.2° ~ 2.2° (Optional 63.0° ~ 2.3°)
	Angle of View (V)	34.0° ~ 1.2° (Optional 37.0° ~ 1.3°)
	Angle of view (D)	69.1° ~ 2.5° (Optional 73.0° ~ 2.6°)
	Aperture Range	F1.6 ~ F4.4
	Optical Zoom	30X
	Digital Zoom	16X
	Shutter	1s to 1/100,000s, Auto / Manual
	Min. Illumination	Color: 0.001 lux @ F1.6, 0 lux (External IR LED ON)
	AGC	Auto / Manual
	Digital Noise Reduction	2D & 3D DNR, Auto / Manual
S/N Ratio	≥55 dB	
Defog	Smart Defog	
WDR	120 dB	

# 2MP EXPLOSION PROOF PTZ CAMERA



## ENC-HPT5Z-30X-23

MODEL	Model No.	ENC-HPT5Z-30X-23
	Type	2MP EXPLOSION PROOF PTZ CAMERA
VIDEO	Max. Resolution	1920x1080
	Video Compression	H.265+, H.265, H.264, MJPEG
	Frame Rate	Main Stream: (1920x1080, 1280x720)@ 50/60fps Sub Stream: (1920x1080, 1280x720, 704x576) @ 25/30fps Third Stream: (640x480, 352x288, 320x240) @ 25/30fps Fourth Stream: (640x480, 352x288, 320x240) @ 25/30fps (Optional)
	Stream Settings	i-Frame, PAL/NTSC, Frame Rate, EIS, SVC
	Video Bit Rate	100 kbps ~ 12 Mbps
	Bitrate Type	CBR, VBR
	Image Settings	Brightness, Contrast, Saturation, Sharpness, Day/Night (Color, Mono, Auto), Flip/Mirror/Rotation, Multiple Scene & Profile
	White Balance	Auto, Day / Night, Tungsten, Manual
	HLC	Supported
	BLC	Supported
	OSD	Supported
ROI	Up to 8 regions	
Privacy Mask	Up to 40 regions ( each scene up to 8 )	
AUDIO	Audio Compression	G.711U, G.711A, RAW_PCM
	Audio I/O	1/1
	Audio Bit Rate	8 ~ 16 Kbps
SMART	Behavior Detection	Intrusion (Perimeter), Crossline (Tripwire), Double crossline ( Double Tripwire)
	Intelligent Identification	Abandoned object (Object Left), Missing Object (Object Lost), Loitering, Multi Loitering, Smoke Detection, Flame Detection
	Statistical Analysis	Face Detection , People Counting, Human & Vehicle Detection, Abnormal Video & Audio Detection, Wrong Way Detection, Illegal Parking, Tampering / Masking / Scene Change, Abnormal Speed
	Alarm Management	Motion Detection, Tampering (Masking), Input & Output Event, Network Alarm, Disk Alarm, Day Night Switch Alarm, Abnormal Audio Alarm, Pre/Post Alarm Recording, Alarm Recording/Snapshot
	Alarm Notifications	E-mail, HTTP, FTP, SD Card & Alarm Out (Event Notification/ Recording/ Snapshot upload through E-mail, HTTP, FTP & SD Card)
	Auto Tracking	Supported **Will be available in next FW version
INTERFACE	Protocols	TCP/IP, UDP, IPv4, IPv6, ICMP, HTTP, HTTPS, FTP, DHCP, DNS, DDNS, RTP, RTSP, RTCP, PPPoE, NTP, UPnP, SMTP , IGMP, 802.1X, Unicast, Multicast, QoS, ARP, SNMP, Telnet, SSL/TLS1.2
	Security	TLS 128 Encryption, IP Filter, User Authentication (Multiple Privilege Level), 802.1X Authentication (EAP-MD5), HTTPS Authentication, RTSP Authentication, Digest Authentication, User Access Log
	Compatibility	ONVIF (S, G, T) , SDK, CGI
	Network	1 x RJ45 10M/100M Self Adaptive Ethernet Port
	Alarm Interface	2 Input / 2 Output
	Serial Interface	1xRS485
	Edge Storage	SD card slot, up to 256 GB
	ANR	Supported
	Built-in Heater	Supported
	Wiper	Supported
	Max. User	32
Client Application	EyeGuard	
PAN AND TILT	Pan Range	360°(Endless)
	Pan Speed	Pan Manual Speed: 0.1°/s ~ 45°/s, Pan Preset Speed: 45°/s
	Tilt Range	-90 ~ +90°
	Tilt Speed	Tilt Manual Speed: 0.1°/s ~ 45°/s, Tilt Preset Speed: 45°/s
	Preset Accuracy	±0.1°
	3D Position	Supported
	Cruise Scan	Supported
	Tour	12 (32 Preset per Tour)
	Pattern	6
	Preset	255
Resume function	Supported	

# 2MP EXPLOSION PROOF PTZ CAMERA



## ENC-HPT5Z-30X-23

MODEL		ENC-HPT5Z-30X-23
	Model No.	ENC-HPT5Z-30X-23
	Type	2MP EXPLOSION PROOF PTZ CAMERA
GENERAL	Power Supply	AC 110V ~ 240V / 24V DC / 24V AC / PoE++ (802.3bt-Type 4)
	Power Consumption	Max. 75W (with thermostat)
	Working Temperature	-40°C ~ 70°C
	Working Humidity	0-95% RH (non-condensing)
	Atmospheric pressure	80 kPa ~ 120 kPa
	Window glass	Strong tempered glass
	Sun shade	Supported
	Ingress Protection	IP68
	Vandal Resistant	IK10(Housing)
	Surge Protection	TVS6000V
	Reset Button	Supported
	Dimensions	390x295x420 mm
Net Weight	40 kg	

Dimension Unit : mm

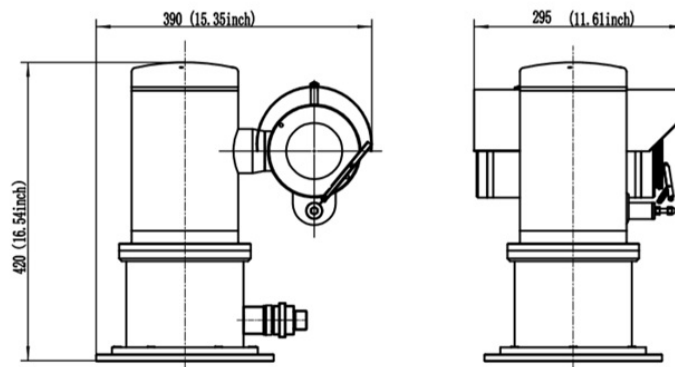

### ORDERING INFORMATION

Part Number	Description	Standard Quantity
ENC-HPT5Z-30X-23	2MP SS316L (Optional SS304) 60fps Explosion Proof IP PTZ Camera with 30X Optical Zoom, Wiper and SD Card Slot Support	1
ENB-BZPW68	Wall Mount Bracket for Eyenor Explosion / Corrosion Proof PTZ Camera	1
ENB-BZPH68	Corner Mount Bracket for Eyenor Explosion / Corrosion Proof PTZ Camera	1
ENB-BZPV68	Pole Mount Bracket for Eyenor Explosion / Corrosion Proof PTZ Camera	1
ENA-EXH010	1 Meter Explosion / Corrosion Proof Hose for Eyenor Explosion / Corrosion Proof Camera	1
ENA-EXH015	1.5 Meter Explosion / Corrosion Proof Hose for Eyenor Explosion / Corrosion Proof Camera	1
ENA-EXH020	2 Meter Explosion / Corrosion Proof Hose for Eyenor Explosion / Corrosion Proof Camera	1

### PACKING INFORMATION

Part Number	Packing Mode	Gross weight(Kg)	Dimension(mm)
ENC-HPT5Z-30X-23	Carton Box	-	-