

5MP CORROSION PROOF BULLET CAMERA



ENC-HBU8M-100R-27

FEATURES

Starlight Illumination
316L Stainless steel construction
2.7-13.5 mm Motorized Lens
Smart IR up to 100 m
ONVIF Profile (S, G, T)
Triple Stream
Audio and Alarm Support
PoE, IP68

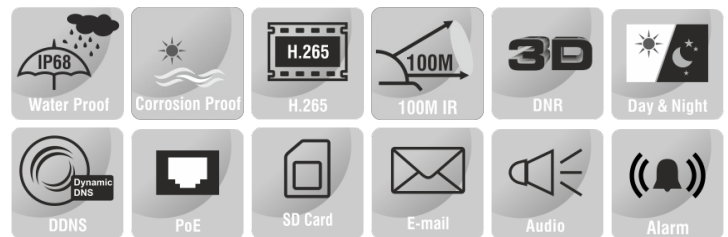

SPECIFICATION

MODEL	Model No.	ENC-HBU8M-100R-27
	Type	5MP CORROSION PROOF BULLET CAMERA
CAMERA	Image Sensor	1/2.8" CMOS Progressive 5.0 MegaPixel
	Day / Night	IR Cut Filter with Auto Switch
	Lens Type	Motorized
	Focal Length	2.7-13.5 mm
	Focus	Auto / Manual
	Iris	DC Auto Iris
	Lens Mount	Φ14
	Angle of View (H)	94.2° ~ 29.3°
	Angle of View (V)	70.3° ~ 22°
	Angle Adjustment	Bracket; Pan: 0~360°, Tilt: 0~75°, Rotate: 0~360°
	Aperture Range	F1.6 ~ F3.3
	Shutter	1s to 1/100,000s
	Min. Illumination	Color: 0.001 lux @ F1.6, B/W: 0 lux with IR
	AGC	Auto / Manual
	Digital Noise Reduction	3D DNR
	S/N Ratio	≥60 dB
Defog	Smart Defog	
WDR	120 dB	
Smart IR	Up to 100 m	
Wavelength	850 nm	
White LEDs	N/A	

5MP CORROSION PROOF BULLET CAMERA



ENC-HBU8M-100R-27

MODEL		ENC-HBU8M-100R-27
VIDEO	Model No.	ENC-HBU8M-100R-27
	Type	5MP CORROSION PROOF BULLET CAMERA
	Max. Resolution	2592x1944
	Video Compression	H.265+, H.265, H.264, MJPEG
	Frame Rate	Main Stream: (2592x1944, 2592x1520, 2560x1440, 2304x1296) @ 25 / 30fps, (1920x1080, 1280x720) @ 50 /60fps Sub Stream: (704x480, 704x240, 640x360, 352x240) @ 30fps, (704x576, 704x288, 640x360, 352x288) @ 25fps Third Stream: (1920x1080, 1280x720, 640x360, 704x480, 704x240, 352x240) @ 30fps, (1920x1080, 1280x720, 640x360, 704x576, 704x288, 352x288) @ 25fps
	Stream Settings	i-Frame, PAL/NTSC, Frame Rate (1~30FPS), EIS, SVC
	Video Bit Rate	32 kbps ~ 16 Mbps
	Bitrate Type	CBR, VBR
	Image Settings	Brightness, Contrast, Saturation, Hue, Sharpness, Rotation/Mirror, Gain, Exposure, Day/Night
	White Balance	Auto, Semi Auto, Sunshine, Daylight, Warm Light, Filament, Nature Light, Lock WB, Manual
	Corridor Mode	Supported
	HLC	Supported
	BLC	Supported
	OSD	Total 8 regions
	OSD Type	Title, Week, Date, Time, Text with different colors and adaptable sizes (16x16, 32x32, 48x48, 64x64, 96x96), Image overlay
	ROI	Up to 8 regions
Privacy Mask	Up to 4 regions	
Heatmap	Supported	
AUDIO	Audio Compression	G.711A, G.711U, ADPCM_D, AAC_LC
	Audio Bit Rate	8 kbps ~ 48 kbps
	Audio I/O	1/1
	Audio Voltage	Input: Level 5V, Input Impedance 1500 ohms Output: Level 3V, Output Impedance 100 ohms
SMART	Behavior Detection	Intrusion (Perimeter), Crossline (Tripwire), Double Crossline (Double Tripwire)
	Intelligent Identification	Loitering, Running, Abandoned Object (Object Left), Missing Object (Object Lost), Parking
	Statistical Analysis	Face Detection (Capture), People Counting, Crowd Detection, On Duty Detection, Helmet Detection, Human & Vehicle Classification, Abnormal Video & Audio Detection
	Alarm Management	Motion Detection, Tampering (Masking), Input & Output Event, IP & MAC Address Conflict, Disk Alarm (Full & RW Error), FTP Server Exception, Abnormal Voltage, Pre/Post Alarm Recording, Alarm Recording/Snapshot
INTERFACE	Protocols	TCP/IP, UDP, IPv4, IPv6, ICMP, HTTP, HTTPS, FTP, NFS, DHCP, DNS, DDNS, RTP, RTSP, RTCP, RTMP, PPPoE, NTP, UPnP, SMTP (SSL/TLS), IGMP, 802.1X, QoS (DSCP), Unicast, Multicast, ARP, SNMP, SSL, Telnet, SFTP (SSH), P2P
	Security	AES Video Encryption, IP Filter, User Authentication (Multiple Privilege Level), 802.1X Authentication (EAP-MD5), HTTPS Authentication, Digest Authentication, User Access Log
	Compatibility	ONVIF Profile (S, G, T), SDK/API/CGI
	Network	1 x RJ45 10M/100M Self Adaptive Ethernet Port
	Alarm Interface	2 Input / 1 Output
	Alarm Voltage	Input (switch type) , Output (3.3V-12V, 10 ohm)
	Serial Interface	1xRS485
	Edge Storage	Micro SD card slot, up to 512 GB
	ANR	Supported
	Built-in Speaker	N/A
	Built-in Heater	Supported (Optional)
	Built-in Fan	Supported
	Cable Interface	Pig Tail
Remote Connection	≤7	
Client Application	EyeConnect	
Web Language	16	

5MP CORROSION PROOF BULLET CAMERA



ENC-HBU8M-100R-27

MODEL		ENC-HBU8M-100R-27
	Type	5MP CORROSION PROOF BULLET CAMERA
GENERAL	Power Supply	AC 110V ~ 240V / 24V DC / 24V AC / PoE+ (802.3at-Type 2)
	Power Consumption	Max. 25W
	Working Temperature	-40 °C ~ 70 °C
	Working Humidity	≤95% RH
	Atmospheric pressure	80 kPa ~ 106 kPa
	Window glass	Strong tempered glasss
	Surge Protection	Supported
	Ingress Protection	IP68
	Corrosion Resistant	Sprayed with Oxygen, Hydrogen Sulphide, Carbon Dioxide and Nitrogen
	Reset Button	Supported
	Dimensions	416.5x166x258 mm
Net Weight	12 kg	

Dimension Unit : mm

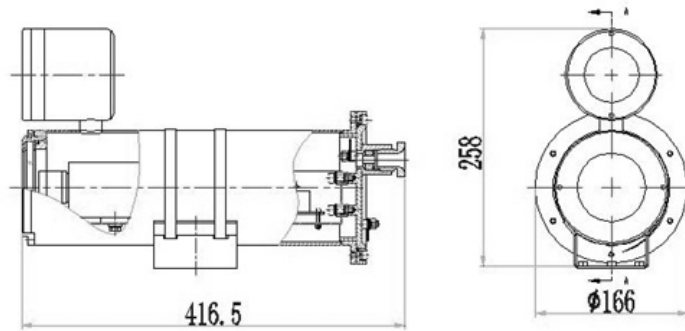

ORDERING INFORMATION

Part Number	Description	Standard Quantity
ENC-HBU8M-100R-27	5MP SS316L Corrosion Proof IR IP H.265 Bullet Camera with 2.7 to 13.5mm Motorized Lens, PoE, SD Card Slot, WDR, Smart Analytics and 100m IR Support	1
ENB-BZUW68	Wall Mount Bracket for Eyenor Explosion / Corrosion Proof Bullet Camera	1
ENB-BZUH68	Corner Mount Bracket for Eyenor Explosion / Corrosion Proof Bullet Camera	1
ENB-BZUV68	Pole Mount Bracket for Eyenor Explosion / Corrosion Proof Bullet Camera	1
ENA-EXH010	1 Meter Explosion / Corrosion Proof Hose for Eyenor Explosion / Corrosion Proof Camera	1
ENA-EXH015	1.5 Meter Explosion / Corrosion Proof Hose for Eyenor Explosion / Corrosion Proof Camera	1
ENA-EXH020	2 Meter Explosion / Corrosion Proof Hose for Eyenor Explosion / Corrosion Proof Camera	1

PACKING INFORMATION

Part Number	Packing Mode	Gross weight(Kg)	Dimension(mm)
ENC-HBU8M-100R-27	Carton Box	-	-