

# CEILING SPEAKER(1.87W-3.75W-7.5W-15W)



## N-4208B

### DESCRIPTION

The N-4208B is a ceiling speaker built-in 70v/100v transformer. The 70v/100v transformer technique reduces line losses on longer distance and allows easy parallel connection of multiple loudspeakers.

The built-in 8"+1.5" coaxial paper speaker driver is designed of wide frequency response 80-20kHz, the multiple power taps 1.87W, 3.75W, 7.5W & 15W are helpful for different applications varies from room size and ambient noise surroundings. The metal grille and ABS baffle are painted in attractive white color. Its flush mount type makes the easy and secure installation.

It is ideal choice for industrial and commercial applications in hotel, school, office and factory where background music and paging is needed.



### FEATURES

- ◆ Built-in 100v/70v transformer
- ◆ Excellent sound quality speaker for music & speech
- ◆ In-ceiling type loudspeaker
- ◆ 8" +1.5" coaxial paper speaker unit
- ◆ Power taps 1.87W, 3.75W, 7.5W & 15W @100V
- ◆ Metal grille & ABS baffle
- ◆ Paint in white color
- ◆ Flush mount easy & secure installation

### SPECIFICATIONS

Model	N-4208B
Power Taps @100V	1.87W, 3.75W, 7.5W, 15W
Power Taps @70V	0.93W, 1.87W, 3.75W, 7.5W
Impedance	Black: Com Blue:5.3KΩ Red:2.6KΩ Green:1.3KΩ White:670Ω
SPL(1W/1M)	90dB
Max. SPL (Rated W/1M)	102dB
Frequency Response (-10dB)	80-20KHz
Finish	Baffle: ABS, White Grille: Steel, White
Speaker Driver	8" x 1 1.5" x 1
Cutout Size	245mm
Dimensions	280x80mm
Weight	1.5Kg
Mounting	Flush-mount dog ears

# CEILING SPEAKER(1.87W-3.75W-7.5W-15W)



N-4208B

## APPEARANCE

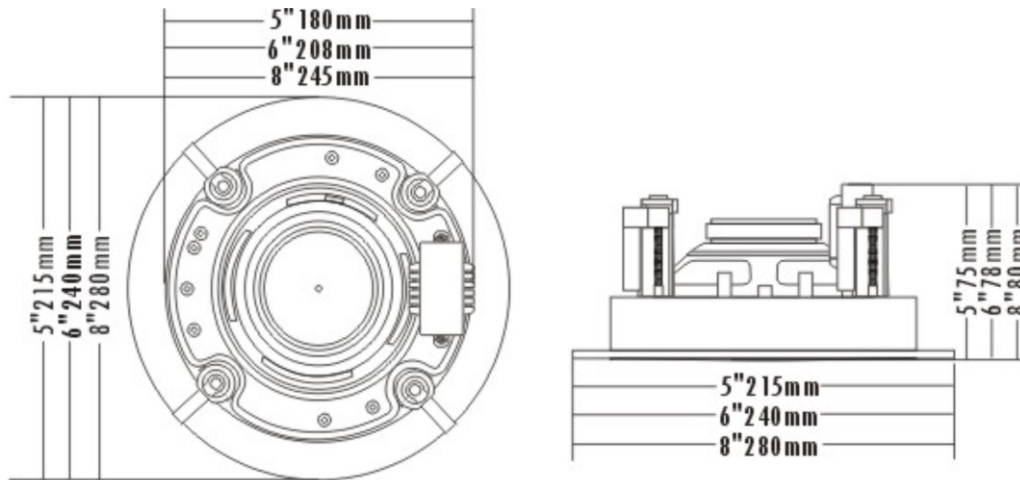

## ORDERING INFORMATION

Part Number	Description	Standard Quantity
N-4208B	Coaxial ceiling speaker (1.87W-3.75W-7.5W-15W)	1 No.

## PACKING INFORMATION

Part Number	Packing Mode	Gross Weight(kg)	Dimensions(mm)
N-4208B	Carton Box	1.8	280x80x280