

2MP MOTORIZED VANDAL DOME CAMERA



ENC-HVD5M-40R-70

FEATURES

2.7 ~ 13.5 mm Motorized Lens

Smart IR up to 40 m

ONVIF Profile (S, G, T)

Quad Stream

Audio and Alarm Support

PoE, IP67, IK10

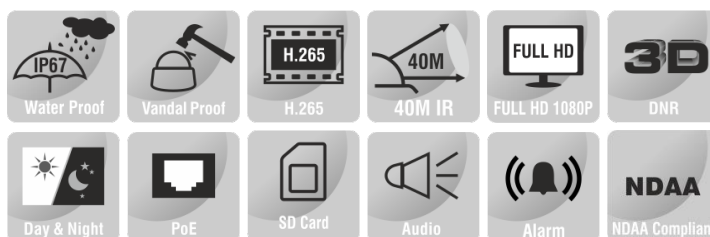

SPECIFICATION

MODEL	Model No.	ENC-HVD5M-40R-70
	Type	2MP MOTORIZED VANDAL DOME CAMERA
CAMERA	Image Sensor	1/2.8" CMOS Progressive 2.0 MegaPixel
	Day/Night	IR Cut Filter with Auto Switch
	Lens Type	Motorized
	Focal Length	2.7 ~ 13.5 mm
	Digital Zoom	16x
	Focus	Auto / Manual
	Iris	Fixed Iris
	Angle of View (H)	101.0° ~ 28.0°
	Angle of View (V)	54.0° ~ 16.0°
	Angle of View (D)	114.0° ~ 35.2°
	Angle Adjustment	Pan 0 ~ 355°, Tilt 0 ~ 80°, Rotate 0 ~ 355°
	Shutter	1s to 1/100,000s, Auto / Manual
	Min. Illumination	Color: 0.001 lux @ F1.2, B/W: 0 lux with IR
	AGC	Auto / Manual
	Digital Noise Reduction	2D & 3D DNR, Auto / Manual
S/N Ratio	≥55 dB	
Defog	Smart Defog	
WDR	120 dB	
Smart IR	Up to 40 m	
Wavelength	850 nm	

★Product specification and availability are subject to change without notice.

2MP MOTORIZED VANDAL DOME CAMERA



ENC-HVD5M-40R-70

MODEL	Model No.	ENC-HVD5M-40R-70
	Type	2MP MOTORIZED VANDAL DOME CAMERA
VIDEO	Max. Resolution	1920x1080
	Video Compression	H.265+, H.265, H.264, MJPEG
	Frame Rate	Main Stream: (1920x1080, 1280x720, D1) @ 50/60fps Sub Stream: (1920x1080, 1280x720, D1) @ 25/30fps Third Stream: (640x480, 352x288, 320x240, 177x144) @ 25/30fps Fourth Stream: (640x480, 352x288, 320x240, 177x144) @ 25/30fps (Optional)
	Stream Settings	i-Frame, PAL/NTSC, Frame Rate, EIS
	Video Bit Rate	100 kbps ~ 12 Mbps
	Bitrate Type	CBR, VBR
	Image Settings	Brightness, Contrast, Saturation, Sharpness, Day/Night (Color, Mono, Auto), Flip/Mirror/Rotation, Multiple Scene & Profile
	White Balance	Auto, Day/Night, Tungsten, Manual
	Corridor Mode	Supported
	HLC	Supported
	BLC	Supported
	OSD	Total 8 regions
	OSD Type	Title, Week, Date, Time, Text with different colors and adaptable sizes, Image overlay
	ROI	Up to 8 regions
Privacy Mask	Up to 4 regions	
AUDIO	Audio Compression	G.711A, G.711U, RAW_PCM
	Audio Bit Rate	8 kbps, 16 kbps, 64 kbps
	Audio I/O	1/1
SMART	Behavior Detection	Intrusion (Perimeter), Crossline (Tripwire), Double Crossline (Double Tripwire)
	Intelligent Identification	Loitering, Multi Loitering, Abandoned Object (Object Left), Missing Object (Object Lost)
	Statistical Analysis	Face Detection , People Counting, Human & Vehicle Detection, Abnormal Video & Audio Detection, Wrong Way Detection, Illegal Parking, Tampering / Masking / Scene Change, Abnormal Speed
	Alarm Management	Motion Detection, Tampering (Masking), Input & Output Event, Network Alarm, Disk Alarm, Day Night Switch Alarm, Abnormal Audio Alarm, Pre/Post Alarm Recording, Alarm Recording/Snapshot
	Alarm Notifications	E-mail, HTTP, FTP, SD Card & Alarm Out (Event Notification/ Recording/ Snapshot upload through E-mail, HTTP, FTP & SD Card)
INTERFACE	Protocols	TCP/IP, UDP, IPv4, IPv6, ICMP, HTTP, HTTPS, FTP, DHCP, DNS, DDNS, RTP, RTSP, RTCP, PPPoE, NTP, UPnP, SMTP , IGMP, 802.1X, Unicast, Multicast, QoS, ARP, SNMP, Telnet, SSL/TLS1.2
	Security	TLS Video Encryption, IP Filter, User Authentication (Multiple Privilege Level), 802.1X Authentication (EAP-MD5), HTTPS Authentication, RTSP Authentication, Digest Authentication, User Access Log
	Compatibility	ONVIF Profile (S, G, T), SDK/CGI
	Network	1 x RJ45 10M/100M Self Adaptive Ethernet Port
	Alarm I/O	1/1
	Edge Storage	SD card slot, up to 256 GB
	ANR	Supported
	Max User	32
	Client Application	EyeGuard
	Power Supply	12V DC, PoE (IEEE 802.3af)
GENERAL	Max. Power Consumption	8.5 W
	Working Temperature	-40 °C ~ 60 °C
	Working Humidity	≥95% RH (non-condensing)
	Ingress Protection	IP67
	Vandal Resistant	IK10
	Surge Protection	TVS4000V
	Reset Button	Supported
	Dimensions	Φ130x112 mm
	Net Weight	0.8 Kg

★Product specification and availability are subject to change without notice.

2MP MOTORIZED VANDAL DOME CAMERA



ENC-HVD5M-40R-70

MODEL	Model No.	ENC-HVD5M-40R-70
	Type	2MP MOTORIZED VANDAL DOME CAMERA

Dimension Unit : mm

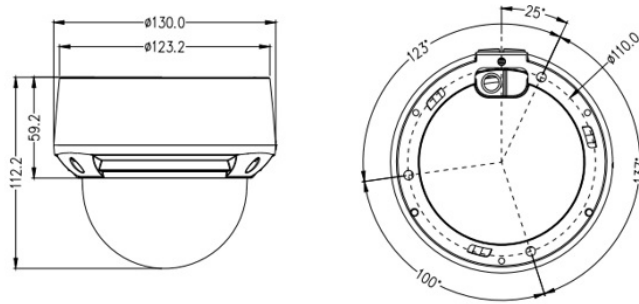

ORDERING INFORMATION

Part Number	Description	Standard Quantity
ENC-HVD5M-40R-70	2MP 60FPS H.265 IR IP Vandal Proof Dome Camera with 2.7 to 13.5mm Motorized Lens, WDR, PoE, SD Card Slot, Smart Analytics and 40m IR Support	1
ENB-BCDJ67	Junction Box for Eyenor Dome Camera	1
ENB-BCDQ66	Pendent Cap for Eyenor Dome Camera	1
ENB-BCDP66	Pendant Mount for Eyenor Dome Camera	1
ENB-BCDW66	Wall Mount for Eyenor Dome Camera	1
ENB-BCDV66	Pole Mount for Eyenor Dome Camera	1
ENB-BCDH66	Corner Mount for Eyenor Dome Camera	1

PACKING INFORMATION

Part Number	Packing Mode	Gross weight(Kg)	Dimension(mm)
ENC-HVD5M-40R-70	Carton Box	-	-

★Product specification and availability are subject to change without notice.