

IP DUAL SENSOR TEMPERATURE DETECTION THERMAL PTZ CAMERA



ENC-HHP6Z-30X-37

FEATURES

400x300 Uncooled VOx Micro Bolometer Detector
Sensitivity $\leq 40\text{mK}$
8/15/25 mm Manual Focus Thermal Lens Optional
Areas / Spot / Line Temperature Measurement Rule Support
17 Color Patterns Support
Strong Wind Resistant, Electronic Image Stabilization
IP67



SPECIFICATION

MODEL	Model No.	ENC-HHP6Z-30X-37									
	Type	IP Dual Sensor Temperature Detection Thermal PTZ Camera									
THERMAL CAMERA	Detector Type	Uncooled VOx Focal Plane Arrays									
	Effective Pixels	400x300 and Image can be scaled up to 704x576									
	Pixel Size	17um									
	Thermal Sensitivity (NETD)	$\leq 40\text{ mK}$									
	Spectral Range	8~14um									
	Image Setting	Brightness, Sharpness, Contrast, Mirror, 2D/3D DNR, Mirror / Flip, FFC									
	Color Palettes	White & Black Hot, Ironbow, Rainbow etc. up to 17 modes									
THERMAL LENS	Lens	Fixed									
	Digital Zoom	16x									
	Focus Control	Manual Focus									
	Focal Length	8/15/25									
	F No.	1.0									
	Angle of View	8mm	15mm	25mm							
		46°(H), 35.3°(V)	25.5°(H), 19.2°(V)	15.4°(H), 11.6°(V)							
	Thermal imaging	Object	Human(1.8mx0.5m)			Vehicle(4mx1.5m)			Fire(1mx1m)		
		Lens	8mm	15mm	25mm	8mm	15mm	25mm	8mm	15mm	25mm
		Detection	235m	441m	735m	722m	1353m	2255m	235m	441m	735m
Recognition		59m	110m	184m	180m	338m	564m	78m	147m	245m	
Identification		29m	55m	92m	90m	147m	282m	39m	74m	123m	
VISIBLE CAMERA	Image Sensor	1/2.8" Sony CMOS									
	Max.Resolution	2048 x1536									
	Focal Length	4.5 ~ 135 mm									
	Optical Zoom	30x									
	Digital Zoom	16x									
	Focus Control	Auto/Manual									
	Iris	P-IRIS									
	Max Aperture	F1.6 ~ F4.4									
	Shutter Speed	1s~ 1/100,000s									
	Min. Illumination	Color: 0.01 lux @ (F1.2, AGC ON), B/W: 0.001 lux									
	AGC	Auto/Manual									
	Angle of View(H)	59.8°~2.3°									
	S/N Ratio	>55dB									
	WDR	120dB									
Illumination Distance	Up to 30m										



IP DUAL SENSOR TEMPERATURE DETECTION THERMAL PTZ CAMERA



ENC-HHP6Z-30X-37

SPECIFICATION

MODEL	Model No.	ENC-HHP6Z-30X-37
	Type	IP Dual Sensor Temperature Detection Thermal PTZ Camera
VIDEO	Video Compression	H.265+, H.265, H.264, MJPEG
	Frame Rate	Main Stream: Thermal: 704x576 @25/30fps; Visible: 2048x1536 @25/30fps Sub Stream: Thermal: CIF @25/30fps; Visible: D1/VGA/640x360/CIF/QCIF/QVGA @25/30fps
	Bit Rate Control	CBR/VBR
	Bit Rate	Thermal: 10Kbps ~ 6Mbps Visible: 100Kbps ~ 12Mbps
	Defog	Supported
	Motion Detection	Supported
	DVE Image Enhance	Supported
	BLC	Supported
	OSD	Supported
	OSD Type	Title, Week, Date, Time, Text with different colors and adaptable sizes (Small / Medium / Big), Image overlay
	ROI	Up to 8 regions
	Privacy Masking	Supported
	TEMPERATURE	Detection Mode
Alarm		Over/Difference Alarm
Accuracy		±2°C / ±2%
Response Time		≤30ms
Measurement range		-40°C ~ 150°C
SMART	Behaviour Detection	Thermal/Visible: Intrusion (Perimeter), Crossline (Tripwire), Double Crossline (Double Tripwire)
	Intelligent Identification	Thermal: Abandoned Object (Object Left), Missing Object(Object Lost) Visible: Loitering, Multi Loitering, Abandoned Object (Object Left), Missing Object(Object Lost)
	Statistical Analysis	Visible: Abnormal Speed, Wrong Way Detection, Illegal Parking, Signal Bad
	Alarm Management	Motion Detection, Tampering Alarm, Disk Full Alarm, Temperature Alarm, Input / Output Alarm, Network Alarm
INTERFACE	Protocols	TCP/IP, UDP, IPv4, IPv6, ICMP, HTTP, HTTPS, FTP, DHCP, DNS, DDNS, RTP/RTCP, RTSP, PPPoE, NTP, UPnP, SMTP, IGMP V2/V3, 802.1x, QoS, Unicast, Multicast, SNMP, ARP, SSL / TLS 1.2
	Security	AES Video Encryption, IP Filter, User Authentication (Multiple Privilege Level), HTTPS Authentication, Digest Authentication, User Access Log
	Compatibility	ONVIF (Profile S, G, T), CGI/SDK
	Network	2x RJ45 10M/100M Self Adaptive Ethernet Port
	Serial Interface	1xRS485
	CVBS Output	Supported
	Edge Storage	SD card slot, up to 128 GB
	Alarm Interface	1 Output
	Heater & Blower	Supported (Optional)
	Max.User access	32
	Client Application	EyeGuard
PAN & TILT	Pan Range	0° ~ 360° (Endless)
	Pan Speed	Pan Manual Speed: 0.01° - 30°/s, Pan Preset Speed: 0.01° ~30° /s;
	Tilt Range	-90° ~ +90°
	Tilt Speed	Tilt Manual Speed: 0.01° ~10° /s, Tilt Preset Speed: 0.01° ~10° /s
	Number of Presets	400
	PTZ Mode	8 Auto Scan, 12 Tour, 6 Track
	Speed Setup	Auto/Manual (0-8)
	Power Off Memory	Supported
Idle Motion	Activate Preset/ Scan/Tour/Pattern if there is no command in the specified period	

IP DUAL SENSOR TEMPERATURE DETECTION THERMAL PTZ CAMERA



ENC-HHP6Z-30X-37

SPECIFICATION

MODEL	
Model No.	ENC-HHP6Z-30X-37
Type	IP Dual Sensor Temperature Detection Thermal PTZ Camera
GENERAL	
Power Supply	DC24V
Max. Power consumption	40W
Working Temperature	-20 °C ~ 60 °C
Working Humidity	95% RH
Casing	Metal
Ingress Protection	IP67
Vandal Resistant	IK10 (Housing)
Surge Protection	TVS6000V
Reset Button	Supported
Dimensions	322×192×177mm
Weight	5Kg

Dimension Unit: mm

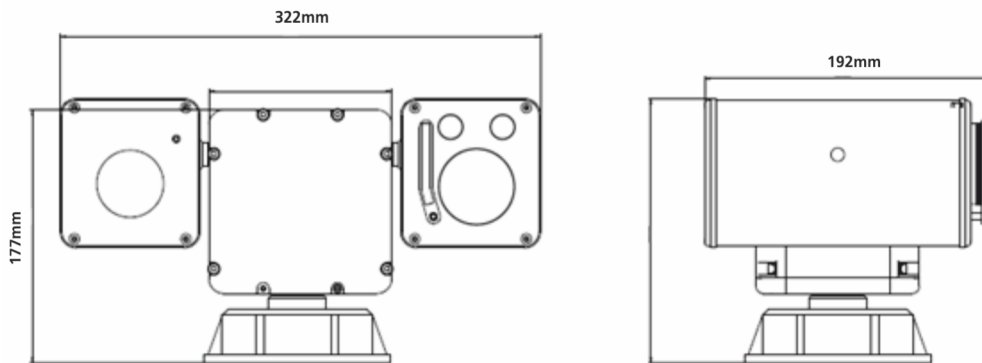

ORDERING INFORMATION

Part Number	Description	Standard Quantity
ENC-HHP6Z-30X-37	3MP IP Dual Sensor Temperature Detection Thermal PTZ Camera with Visible Lens of 30X Optical Zoom and Thermal Imaging Camera with 400*300 Thermal Resolution and SD Card Slot Support	1

PACKING INFORMATION

Part Number	Packing Mode	Gross Weight (kg)	Dimension (mm)
ENC-HHP6Z-30X-37	Carton Box	-	-