

INTELLIGENT TRAFFIC STROBE LAMP



ENI-ISA010-040R

FEATURES

40 pcs LED
32W IR Illuminator
40 m Distance Support
IP66



SPECIFICATION

MODEL	Model No.	ENI-ISA010-040R
	Type	INTELLIGENT TRAFFIC STROBE LAMP
GENERAL	Beam Angle	10°
	Beam Distance	40 m
	Best Distance for LPR	20 ~ 40 m
	Flash Trigger Method	Self Adaptation
	Synchronization Port	One Port Strobe Trigger Input
	Response Time	≤20μs
	Design Lifetime	≥50000 Hrs
	Color	White
	LED	40 pcs LED
	Wavelength	850 nm
	Power Supply	110 ~ 220V AC
	Power Consumption	≤32W
	Working Temperature	-40 °C ~ 70 °C
	Working Humidity	≤90%
Ingress Protection	IP66	
Surge Protection	Common mode: 6KV, Differential mode: 3KV	
Material	Aluminium Die-Casting Housing	
Panel	Tempered glass	
Dimensions	216x200x62 mm	
Net Weight	2.8 kg	
INSTALLATION	Power	The Power and LED Panel Wires must be Oriented Downward to Prevent Water Intrusion.
	Earthing	Lighting Safety Precautions must be Taken and Power Wires must be Grounded.
	Settings	Gently Modify the Bolt of Brightness, Sensor and Time.
	Installation	Professional Electricians or Quality Technicians Should Install and Adjust.
	Caution	Do Not Open the Case and Remove the Power Supply.

INTELLIGENT TRAFFIC STROBE LAMP



ENI-ISA010-040R

MODEL	Model No.	ENI-ISA010-040R
	Type	INTELLIGENT TRAFFIC STROBE LAMP

Dimension Unit : mm

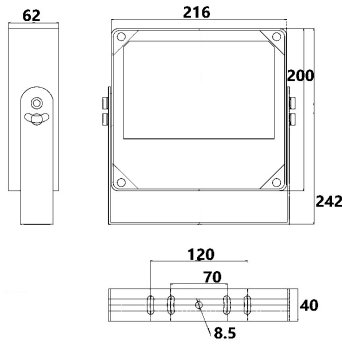

ORDERING INFORMATION

Part Number	Description	Standard Quantity
ENI-ISA010-040R	IR Strobe Illuminator with 40 Pieces High Power IR LED, 10° Beam Angle, 40m IR and IP66 Support	1

PACKING INFORMATION

Part Number	Packing Mode	Gross weight(Kg)	Dimension(mm)
ENI-ISA010-040R	Carton Box	-	-