

WALL MOUNT BRACKET FOR EYENOR PTZ DOME CAMERA



ENB-PW66



SPECIFICATION

MODEL	Model No.	ENB-PW66
	Type	Wall Mount Bracket for Eyenor PTZ Dome Camera
BRACKET	Application	Indoor or outdoor, Wall installation for PTZ Dome camera
	Material	Aluminum alloy
	Dimensions	230.3x141x201.5mm
	Weight	0.79kg

Dimension Unit: mm

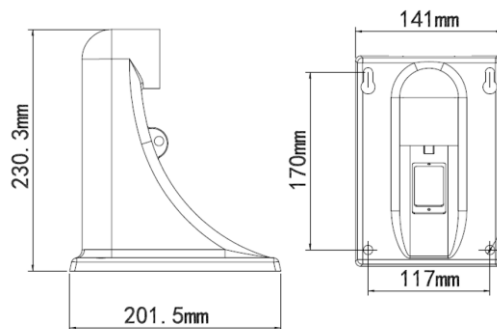

Ordering Information

Part Number	Description	Standard Quantity
ENB-PW66	Wall Mount Bracket for Eyenor PTZ Dome Camera	1

Packing Information

Part Number	Packing Mode	Gross Weight (kg)	Dimension (mm)
ENB-PW66	Carton Box	0.79	230.3x141x201.5

