

2MP H.265 IR IP VANDAL PROOF DOME CAMERA



ENC-HVD5F-30R-68

FEATURES

- 1/2.7" Progressive Scan CMOS
- 2.8mm (3.6mm optional)
- 25fps/30fps@2MP(1920*1080)
- Triple Streams
- Smart IR Up to 30m
- Low bitrate, Excellent low light performance
- WDR, 3D DNR
- ROI, Defog, HLC, Corridor mode, DIS
- IP66, IK10



UL No: **E491809**

Field Of View

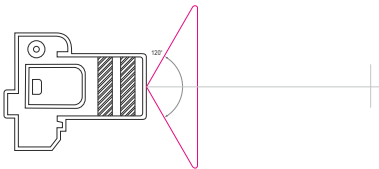

SPECIFICATION

MODEL	Model No.	ENC-HVD5F-30R-68
	Type	2MP H.265 IR IP Vandal Proof Dome camera
CAMERA	Image Sensor	1/2.7" Progressive Scan CMOS
	Effective Pixels	1920(H)×1080(V)
	Scanning System	Progressive
	Electronic Shutter	1/5-1/20000s
	Min. illumination	Color:0.01Lux@(F1.2,AGC ON) , B/W:0Lux@(IR LED ON)
	S/N Ratio	>55dB
	IR Range	Up to 30m
	IR On/Off Control	Auto/ Manual
LENS	Pan/Tilt/Rotation Range	Pan:0°~355°, Tilt:0°~80°, Rotation:0°~355°
	Lens Type	Fixed
	Iris	Fixed Iris
NETWORK	Focal Length	2.8mm(3.6/6mm optional)
	Protocols	IPv4/IPv6, 802.1x, HTTP, HTTPS, TCP/IP, UDP/IP, RTSP, DHCP, NTP, RTCP/RTP, PPPoE, SMTP, DNS, UPnP, FTP, ARP, SNMP
	Interoperability	ONVIF
	Streaming Method	Unicast
	Max. User Access	10 Users
	Web Viewer	<IE11, Chrome, Firefox
	Smart Phone	IOS, Android
	IVS	Perimeter, Single Virtual Fences, Double Virtual Fences, Loiter, Multi Loiter, Object Left, Object Removed, Abnormal Speed, Converse, Illegal



2MP H.265 IR IP VANDAL PROOF DOME CAMERA



ENC-HVD5F-30R-68

SPECIFICATION

MODEL	Model No.	ENC-HVD5F-30R-68
	Type	2MP H.265 IR IP Vandal Proof Dome camera
VIDEO	Compression	H.265+, H.265, H.264, MJPEG
	Max. Resolution	1080P(1920×1080)
	Streaming Capability	3 Streams
	Stream/Frame Rate	Stream1: 1920×1080/1280×720 @25/30fps Stream2: D1/VGA/640×360/CIF/QVGA @25/30fps Stream3: VGA/CIF/QVGA @25/30fps
	Bit Rate Control	CBR/VBR
	Bit Rate	Stream1: 500kbps~12000kbps Stream2: 100kbps~6000kbps Stream3: 100kbps~3000kbps
	Day/Night	ICR
	Image Enhancement	HLC / Defog / WDR (120dB)
	White Balance	Support
	Gain Control	Auto/Manual
	Noise Reduction	2D/3D DNR
	EIS	Support
	Smart IR	Support
	Mirror	Support
	ROI	Support
	Motion Detection	Support
Privacy Masking	Support	
GENERAL	Ethernet	1 Ethernet (10/100 Base-T) RJ-45 Connector
	Power Supply	DC12V/PoE
	Power Consumption	5W
	Operating Temp.	-30°C ~ 50°C
	Operating Humidity	Less than 90% RH
	Ingress Protection	IP66, IK10
	Casing	Metal
	Dimensions	110×110×85.4mm
Net Weight	0.39Kg	

Dimension Unit: mm

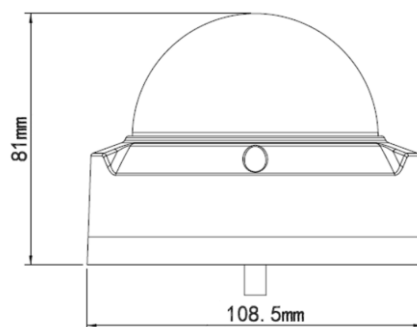

Ordering Information

Part Number	Description	Standard Quantity
ENC-HVD5F-30R-68	2MP H.265 IR IP Vandal Proof Dome camera with 2.8 (Optional 3.6mm) Fixed lens, PoE, WDR, Analytic features and 30m IR Support	1

Packing Information

Part Number	Packing Mode	Gross Weight (kg)	Dimension (mm)
ENC-HVD5F-30R-68	Carton Box	0.39	110×110×85.4

