

WALL MOUNT BRACKET FOR BOX CAMERA



ENB-BW67

FEATURES

Anti-Corrosive and Ultraviolet-Proof Material to Enhance Outdoor Durability

Easy and Flexible Installation

IP67-rated



SPECIFICATION

MODEL	Model No.	ENB-BW67
	Type	WALL MOUNT BRACKET FOR BOX CAMERA
GENERAL	Application	Indoor, Wall Installation for Box Camera Housing
	Dimensions	140 x 88 x 374 mm
	Weight	0.8kg
	Max. Load Support	10kg
	Material	Aluminum Alloy
	Adjustable Range	Horizontal: 360°; Vertical: -45° ~ 0°

Dimension Unit : mm

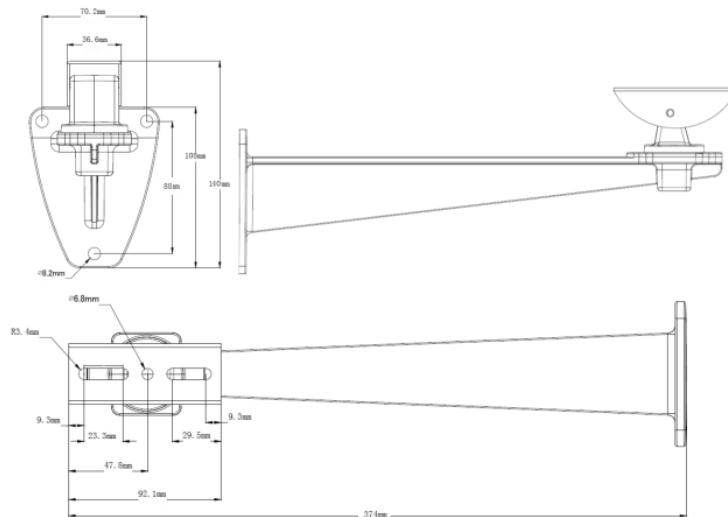

WALL MOUNT BRACKET FOR BOX CAMERA



ENB-BW67

ORDERING INFORMATION

Part Number	Description	Standard Quantity
ENB-BW67	Wall Mount Bracket for Eyenor Box Camera	1

PACKING INFORMATION

Part Number	Packing Mode	Gross weight(Kg)	Dimension(mm)
ENB-BW67	Carton Box	-	-