

5MP PTZ DOME CAMERA



ENC-HPT8Z-150R-92

FEATURES

Starlight Illumination
 23X Optical Zoom
 Smart IR up to 150 m
 ONVIF Profile (S, G, T, M)
 Triple Stream
 Audio and Alarm Support
 PoE+, IP67

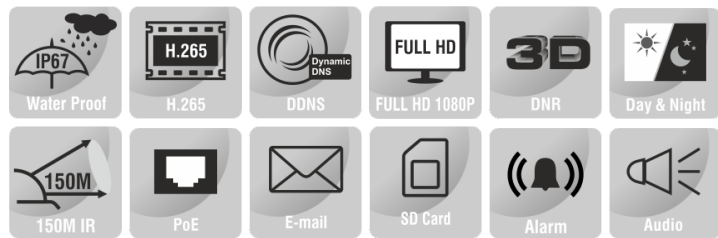

SPECIFICATION

MODEL	Model No.	ENC-HPT8Z-150R-92
	Type	5MP PTZ DOME CAMERA
CAMERA	Image Sensor	1/2.8" CMOS Progressive 5.0 MegaPixel
	Day / Night	IR Cut Filter with Auto Switch
	Lens Type	Motorized Zoom Lens
	Focal Length	5 ~ 115 mm
	Focus	Auto / Semi Auto / Manual
	Iris Type	Auto Iris
	Angle of View (H)	58.0° ~ 3.0°
	Angle of View (V)	39.7° ~ 2.2°
	Angle of View (D)	70.2° ~ 3.7°
	Aperture Range	F1.6 ~ F3.6
	Optical Zoom	23X
	Digital Zoom	16X
	Zoom Speed	<5s
	Shutter	1s to 1/100,000s
	Min. Illumination	Color: 0.001 lux @ F1.6, B/W: 0 lux with IR
	AGC	Auto / Manual
	Digital Noise Reduction	2D & 3D DNR, Auto / Manual
	S/N Ratio	≥60 dB
	Defog	Supported
	WDR	120 dB
Smart IR	Up to 150 m	
Laser IR	N/A	
Wavelength	850 nm	
White LEDs	N/A	

5MP PTZ DOME CAMERA



ENC-HPT8Z-150R-92

MODEL	Model No.	ENC-HPT8Z-150R-92
	Type	5MP PTZ DOME CAMERA
VIDEO	Max. Resolution	2880x1620
	Video Compression	H.265+, H.265, H.264, MJPEG
	Frame Rate	Main Stream: (2880x1620, 2688x1520, 2560x1440, 2304x1296, 1920x1080, 1280x720) @ 25/30fps Sub Stream: (704x480, 704x240, 640x360, 352x240) @30fps, (704x576, 704x288, 640x360, 352x288) @25fps Third Stream: (704x480, 704x240, 640x480, 352x240) @30fps, (704x576, 704x288, 640x480, 352x288) @25fps
	Stream Settings	i-Frame, PAL/NTSC, Frame Rate, EIS, SVC
	Video Bit Rate	32 kbps ~ 16 Mbps
	Bitrate Type	CBR, VBR
	Image Settings	Brightness, Contrast, Saturation, Hue, Sharpness, Rotation/Mirror, Gain, Exposure, Day/Night
	White Balance	Auto, Semi Auto, Sunshine, Daylight, Warm Light, Filament, Nature Light, Lock WB, Manual
	Corridor Mode	N/A
	HLC	Supported
	BLC	Supported
	OSD	Total 5 regions
	OSD Type	Title, Week, Date, Time, Text with different colors and adaptable sizes (16x16, 24x24, 32x32, 48x48, 64x64, 96x96), Image overlay
	ROI	Up to 7 regions
Privacy Mask	Up to 4 regions	
Heatmap	Supported	
AUDIO	Audio Compression	G.711A, G.711U, ADPCM_D, AAC_LC
	Audio Bit Rate	8 kbps ~ 48 kbps
	Audio I/O	1/1
	Audio Voltage	Audio input, level 5V, input impedance 1500 ohms; Audio output, level 3V, output impedance 100 ohms
	Built-in Mic	N/A
SMART	Behavior Detection	Intrusion (Perimeter), Crossline (Tripwire), Double Crossline (Double Tripwire)
	Intelligent Identification	Loitering, Running, Abandoned Object (Object Left), Missing Object (Object Lost), Parking
	Statistical Analysis	Face Detection , On Duty Detection, Human & Vehicle Classification, Abnormal Video & Audio Detection, Crowd Detection, People Counting, Helmet Detection
	Alarm Management	Motion Detection, Tampering (Masking), Input & Output Event, IP Address Conflict, Mac Address Conflict, FTP Server Exception
	Alarm Notification	E-mail, HTTP, FTP, SD Card & Alarm Out (Event Notification / Recording / Snapshot upload through E-mail, HTTP, FTP, & SD Card)
	Auto Tracking	N/A
INTERFACE	Protocols	TCP/IP, UDP, IPv4, IPv6, HTTP, HTTPS, FTP, DHCP, DNS, DDNS, RTP, RTSP, RTMP, PPPoE, NTP, NFS, UPnP, SMTP (SSL/TLS), QoS , 802.1x, Unicast, Multicast, SNMP, SFTP(SSH), SMB, CIFS, P2P
	Security	AES Video Encryption, IP Filter, User Authentication (Multiple Privilege Level), HTTPS Authentication, Digest Authentication, User Access Log
	Compatibility	ONVIF Profile (S, G, T, M), SDK/API/CGI *Profile M will be available in updated version
	Network	1 x RJ45 10M/100M Self Adaptive Ethernet Port
	Alarm Interface	1 Input / 1 Output
	Alarm Voltage	Input (switch type) , Output (3.3V-12V, 10 ohm)
	USB	N/A
	Edge Storage	Built-in MicroSD card slot, up to 512 GB
	ANR	Supported
	Heater	N/A
	Fan	Supported
	Cable Interface	Pig Tail
Remote Connection	≤7	
Client Application	EyeConnect	
Web Language	15	

5MP PTZ DOME CAMERA



ENC-HPT8Z-150R-92

MODEL		ENC-HPT8Z-150R-92
Type		5MP PTZ DOME CAMERA
PAN AND TILT	Pan Range	360° (Endless)
	Pan Speed	Pan Manual Speed: 0.1°/s ~ 120°/s, Pan Preset Speed: 120°/s
	Tilt Range	-16° ~ 90° (Auto flip)
	Tilt Speed	Tilt Manual Speed: 0.1°/s ~ 120°/s, Tilt Preset Speed: 120°/s
	Preset Accuracy	±0.4°
	3D Position	Supported
	Cruise	16, up to 32 presets per cruise
	Scan	8
	Pattern	8, each with 600s memory or 1000 orders
	Number of preset	500
	Power off Recovery	Supported
GENERAL	Power Supply	12V DC, PoE+ (IEEE 802.3at)
	Max. Power Consumption	8.1 W (IR OFF), 19.4 W (IR ON)
	Working Temperature	-40°C ~ 70 °C
	Working Humidity	0-95% RH (non-condensing)
	Ingress Protection	IP67
	Vandal Resistant	IK10 (Housing)
	Surge Protection	TVS6000V
	Reset Button	Supported
	Accessories	Adaptor (included), Wall Mount Bracket (included)
	Optional Accessories	Pole Mount Bracket, Corner Bracket, Connector, Junction Box
Dimensions	Φ161×276 mm	
Net Weight	2.2 kg	

Dimension Unit : mm

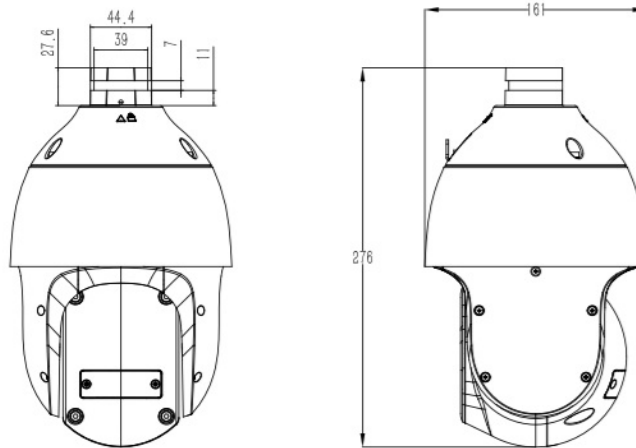

5MP PTZ DOME CAMERA



ENC-HPT8Z-150R-92

ORDERING INFORMATION

Part Number	Description	Standard Quantity
ENC-HPT8Z-150R-92	5MP Starlight IR IP H.265 PTZ Dome Camera with 23X Optical Zoom, PoE+, SD Card Slot, Smart Analytics and 150m IR Support	1
ENB-BTPW65	Eyenor Wall Mount Bracket for 4" PTZ Camera (Included in device package)	1
ENB-BTPH66	Eyenor Outer Corner Bracket for PTZ Camera	1
ENB-BTPV66	Eyenor Pole Mount Bracket for PTZ Camera	1
ENB-BTPD66	Eyenor Connector for PTZ Camera	1
ENB-BTPJ66	Eyenor Junction Box for PTZ Camera	1

PACKING INFORMATION

Part Number	Packing Mode	Gross weight(Kg)	Dimension(mm)
ENC-HPT8Z-150R-92	Carton Box	3.9 kg	250x250x445