

30W Explosion Proof Horn Speaker



DESCRIPTION

The NVS-11150030HS is a 30W Explosion Proof Horn Speaker with built in 100V/70V transformer. The technique of using 70V/100V transformers reduces power loss over long distances and enables convenient connection of multiple speakers. The horn speaker driver integrated into the system has a wide frequency response of 300-13KHz, while the power taps of 7.5W and 15W provide flexibility for different situations depending on room size and surrounding noise levels. This speaker is an excellent choice for outdoor industrial and commercial applications such as parking areas, parks, gardens, corridors, and playgrounds where paging systems are necessary.

FEATURES

- ⦿ Built-in 100V/70V transformer
- ⦿ Explosionproof projector type loudspeaker
- ⦿ Supreme longer distance dispersion horn speaker
- ⦿ Aluminum enclosure and aluminum bracket
- ⦿ Explosion-proof Level - Ex nA IIC T6 Gc (Complied)

Specifications	
Model	NVS-11150030HS
Frequency Response	300Hz-13KHz
Sensitivity (1M,1W)	102dB±3dB
Impedance	Black-COM White-330Ω Green-670Ω
Power Taps @100V	15W, 30W
Power Taps @70V	7.5W,15W
Waterproof Level	IP66
Weight	2.1Kg
Dimension	247×247×290mm

NVS-11150030HS



30W Explosion Proof Horn Speaker

DIMENSION

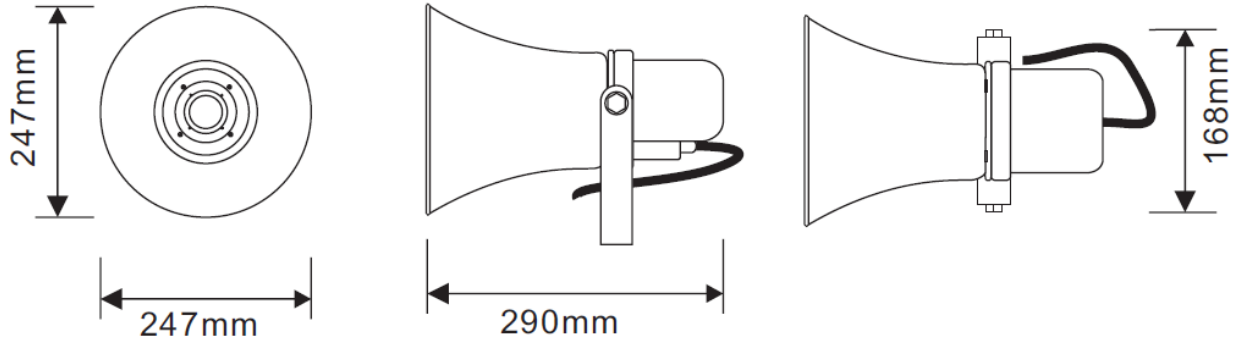

ORDERING INFORMATION

Part Number	Description	Standard Quantity
NVS-11150030HS	30W Explosion Proof Horn Speaker	01