

CORROSION PROOF HOUSING



ENH-BZT68X0R

FEATURES

316L Stainless Steel Construction

Strong tempered glass

IP68



SPECIFICATION

MODEL	Model No.	ENH-BZT68X0R
	Type	CORROSION PROOF HOUSING
GENERAL	Material	316L Stainless Steel Construction
	IR Distance	100 m
	Atmospheric Pressure	80KPa ~ 106Kpa
	Working Temperature	-20° ~ +60°C
	Built-in Heater	Supported (Optional)
	Cooling Kit	Supported (Optional)
	Window Glass	Strong tempered glass
	Working Humidity	≤95%
	Ingress Protection	IP68
	Voltage Input	AC 100 ~ 240V / AC24V / PoE
	Cable Output Gland	2*G 3/4 / M25*1.5 / M27*1.25
	Dimensions (L x W x H)	Inner: 300x75x75 mm Outer: 416.5x166x258 mm
	Weight	12 Kg
Accessories	Wall Mount Bracket	

Dimension Unit : mm

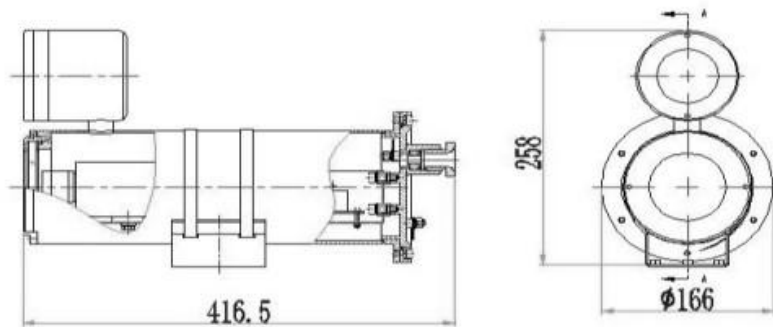

ORDERING INFORMATION

Part Number	Description	Standard Quantity
ENH-BZT68X0R	Corrosion Proof Housing for Eyenor Box Camera with 100m IR, Wall Mount Bracket and IP68 Rating	1

PACKING INFORMATION

Part Number	Packing Mode	Gross weight(Kg)	Dimension(mm)
ENH-BZT68X0R	Carton Box	-	-